

IF IT ROLLS..... WE CAN MOVE IT!®



Pedestrian operated

Maintenance-free gel batteries

On-board battery charger

10mm steel chassis

Smooth variable speed control

Solid lugged rubber tyres

Standard & bespoke attachments

PUSH / PULL CAPACITY....from 2,000Kgs up to 100,000 Kgs



SUPER PUSHER

**Nu-Star Material Handling Ltd.
Unit C, Ednaston Business Centre
Ednaston
Derbyshire DE6 3AE**

**Tel: +44 (0) 870 443 5646
Fax: +44 (0) 870 443 5647
Email: enquiries@nu-starmhl.com
Web: www.nu-starmhl.com**

SUPER PUSHER

Benefits	Features	Accessories
Significant productivity gains – either through a reduction in man-power required to move loads, and/or increased speed of moving loads.	Electrically powered, utilising maintenance-free (military specification), gel batteries with matched on-board battery charger enabling opportunity charging at any time.	Wide range of standard and bespoke attachments enabling connection to customer specific applications.
Assists with compliance of Health & Safety guidelines which limit the manual pushing/pulling performed by one person.	Fully programmable control system enabling speed and acceleration / deceleration characteristics to be set according to load and environment.	Audible motion bleeper & solid state IP65 weatherproof xenon safety beacon.
Fingertip control and compact size make the unit easy to manoeuvre.	Automatic braking, emergency reverse, wheel guards, hand guards & safety horn.	External electrical take-off for complimentary 12, 24 & 36v devices.
Transaxle design allows the unit to operate on uneven surfaces, indoors or outdoors.	Solid rubber 3-ply lugged tyres to maximise traction.	Wireless control & Intrinsically Safe solutions designed to suit.

TECHNICAL SPECIFICATION

Motor type..... 36 Volt D.C.

Drive mechanism.....2 x Chain & Sprocket

Gearbox.....Single speed reduction gearbox, with differential

Controller.....Fully programmable, with diagnostic facility

Batteries..... 3 x 90 Amp/Hour Dryfit, Gel type. Sealed & Maintenance Free

Battery charger..... On-Board, 3 stage, 3 x 10 Amp circuits

Push/Pull Capacity.....Up to 150,000Kgs (Subject to rolling resistance of load)

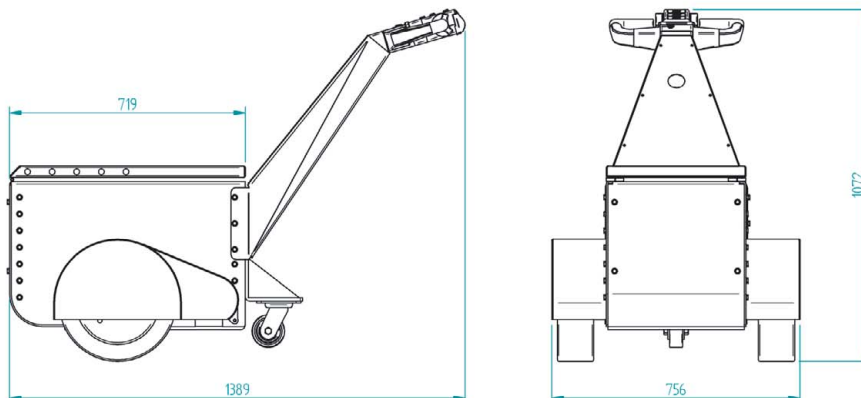

Nu-Star Material Handling Ltd

A member of the NuStar Inc. Group of Companies

Tel: +44 (0) 870 443 5646
Fax: +44 (0) 870 443 5647
Email: enquiries@nu-starmhl.com
Web: www.nu-starmhl.com