

# **IF IT ROLLS..... WE CAN MOVE IT!®**



**Pedestrian Operated**

**Battery Powered**

**Robust Steel Construction**

**Smooth Variable Speed Control**

**Mono Drive Wheel**

**Electric Lift/Lower Attachment**

**Complete control of 4 swivel  
castor loads**

**PUSH / PULL CAPACITY.....from 100Kgs up to 2,000 Kgs**



**Nu-Star Material Handling Ltd.  
Unit C, Ednaston Business Centre  
Ednaston  
Derbyshire DE6 3AE**

## **POWER TUG®**

**Tel: 44 (0) 870 443 5646  
Fax: 44 (0) 870 443 5647  
Email: enquiries@nu-starmhl.com  
Web: www.nu-starmhl.com**

# POWER TUG®

Benefits	Features	Accessories
Significant Productivity gains - either through a reduction in man power required to move loads, and/or increased speed of moving loads.	Electrically powered with on-board charger (110V or 240V) safety horn and hand guards.	97dB Audible motion bleeper.
Assists with compliance of Health & Safety guidelines which limit the manual pushing / pulling performed by one person.	Fully programmable control system enabling speed and acceleration / deceleration characteristics to be set according to load and environment.	Safety strobe.
Fingertip control and compact size make the unit easy to manoeuvre.	Automatic braking and emergency reverse.	External electrical take-off for complimentary devices e.g. Lift Tables.
Mono-drive wheel (with stabilising castors) allows the unit to operate on uneven surfaces, indoors or outdoors.	Polyurethane drive wheel outer with alternative tread patterns and material specifications.	Wide range of standard and bespoke attachments enabling connection to your load.

## TECHNICAL SPECIFICATION

<b>Motor type</b> .....	24 volt D.C.—600W
<b>Drive mechanism</b> .....	Planetary Gearbox, 18:1 reduction, through mono-drive wheel
<b>Controller</b> .....	Fully programmable digital, with diagnostic facility Four quadrant, full bridge power output stage
<b>Batteries</b> .....	2 x 60 Amp/hour Dryfit, Gel type Sealed & Maintenance Free
<b>Battery charger</b> .....	On-Board, 3 stage 2 x 10 Amp circuits (110v or 240v input)
<b>Push / Pull Capacity</b> .....	Up to 2,000Kgs (Subject to rolling resistance of load)

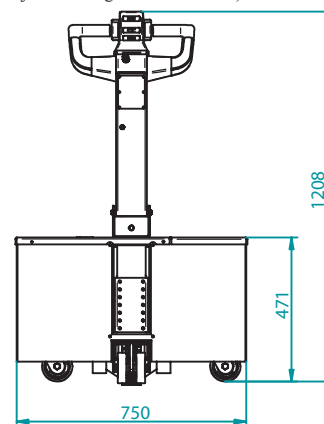
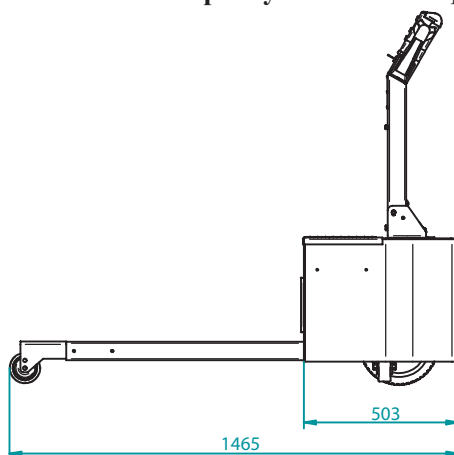

**Nu-Star Material Handling Ltd**

A member of the NuStar Inc. Group of Companies

**Tel:** 44 (0) 870 443 5646  
**Fax:** 44 (0) 870 443 5647  
**Email:** [enquiries@nu-starmhl.com](mailto:enquiries@nu-starmhl.com)  
**Web:** [www.nu-starmhl.com](http://www.nu-starmhl.com)